

INSULATED RIMBOARD INSTALLATION INSTRUCTIONS

DECK ATTACHMENT

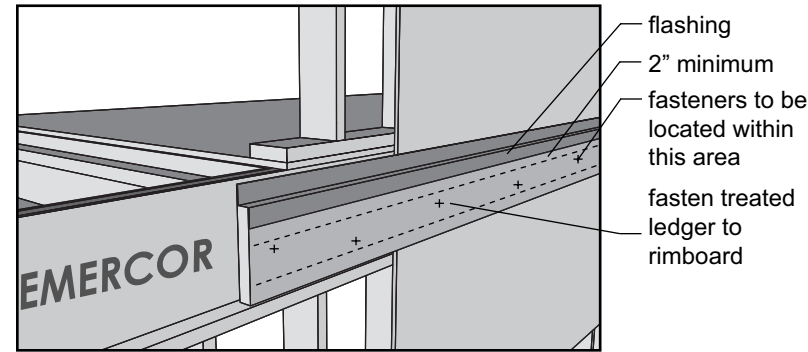

FASTENING REQUIREMENTS

Deck ledger fastening factored resistances:

Fastener Type	Quantity	Size	Load (LBS)
#8 screw	3	4" lg	145
12d nail	3	3 1/4"	183*
1/2" Thru bolt	1	5"	325
1/2" Lag screw	1	5"	270**
3/8" Lag screw	1	5"	240**

* Nail capacity is equivalent to conventional nailing into 2 x 10 spruce.

** Recommended: Use 2 x 4 blocking with lag screws. Use 2 x 4 blocking per ledger fastener - fasten to rimboard with 2 - 3" box nails top/bottom chords.

Note: lag screws must be installed in accordance with wood design manual.

DECK ATTACHMENT WITH CANTILEVER

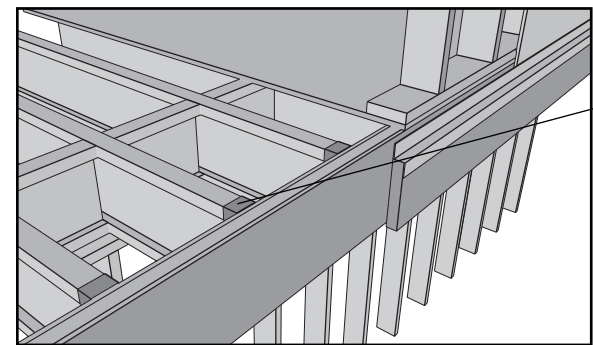

Note: Use inverted hangers to support rimboard reaction

Technical Assistance and Product Information:

1-866-EMERCOR
www.emercor.com
info@emercor.com

EMERCOR Ltd.
104 Commercial Court
Calgary, Alberta CANADA T3Z 2A5

CANTILEVER - OUTSIDE EDGE

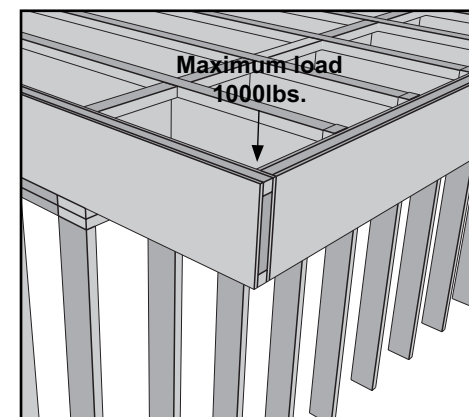

Note: Maximum allowable concentrated load on end of cantilever is 1000lbs.
Use full 8' rimboard panel at cantilever

CANTILEVER - INSIDE EDGE

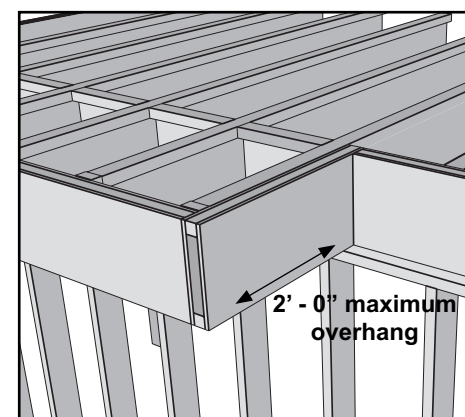

CANTILEVER - ANGLED

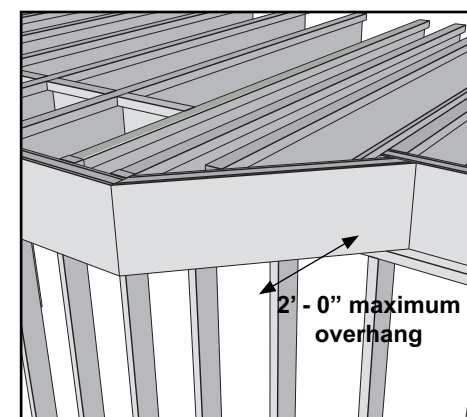

PROUDLY DISTRIBUTED BY:
Your Preferred Floor Supplier

EMERCOR

© 2006 EMERCOR Ltd. Printed in CANADA

EMERCOR

INSULATED RIMBOARD INSTALLATION INSTRUCTIONS

NOVEMBER 2006

MOISTURE RESISTANT • ENERGY EFFICIENT • EASY INSTALLATION

ENGINEERED TO SUPPORT VERTICAL AND LATERAL LOADS, EMERCOR'S INSULATED RIMBOARD PROVIDES SUPERIOR INSULATION AND PROTECTION FROM MOISTURE AND MICROBIAL GROWTH OCCURRING AT THE FLOOR SYSTEM.

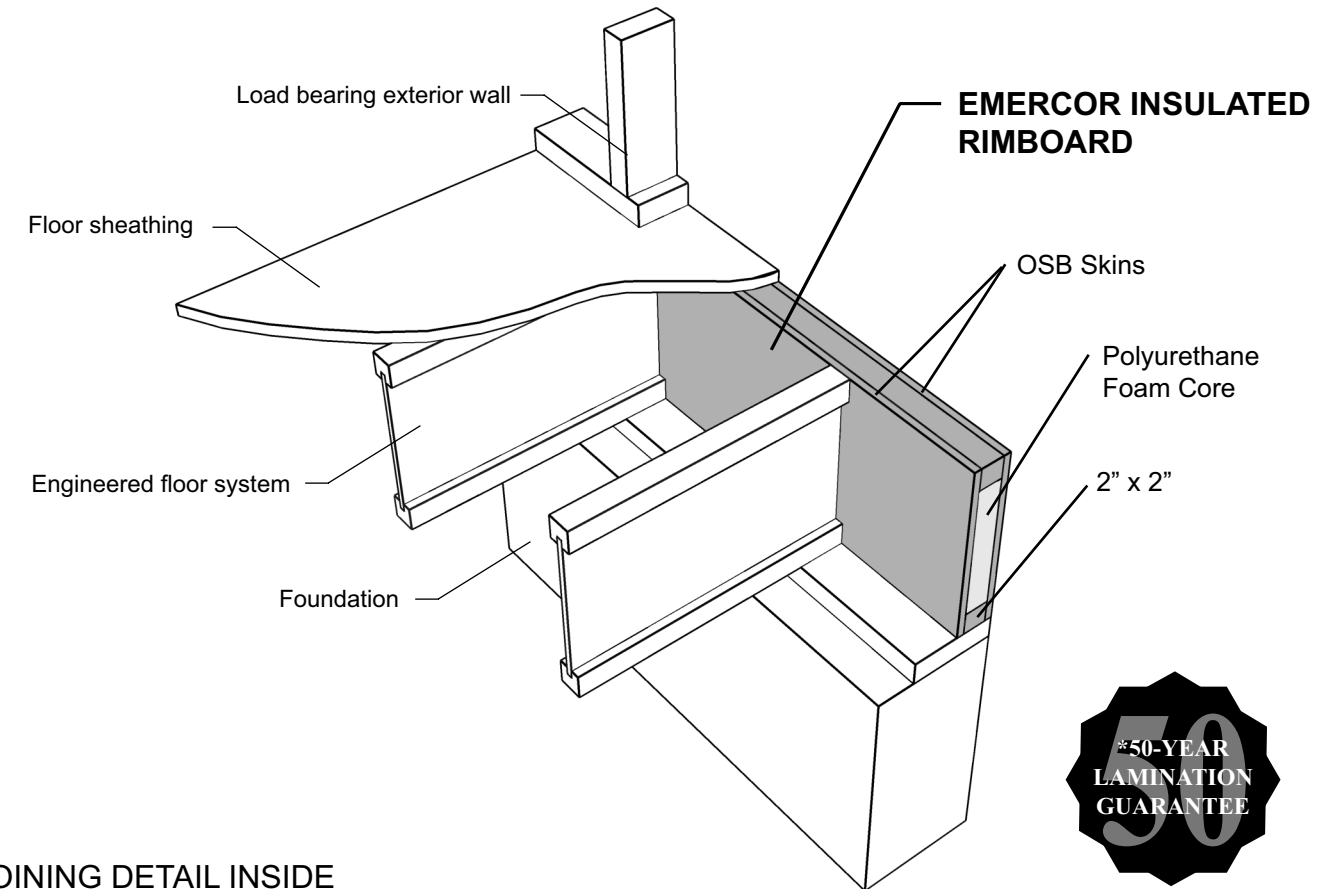

NEW JOINING DETAIL INSIDE

SPECIFICATIONS

Thickness: 2 7/16"
Widths: 9 1/2", 11 7/8", 14", 16", 18", 20", 22", 24"
Length: 8' Panels
Exterior Finish: OSB
Thermal Resistance: R 14
Vapor Resistance: 2.6 ng/Pam²s - Type 1
Air Resistance: Effective Air Barrier
Evaluation: ICC-ESR 1354
CCMC 13254-R

Allowable Stress Design (ASD) *

Rimboard Depth	Uniform Compressive Strength in Parallel (LBS/LF)	Horizontal Load Transfer Capacity (LBS/LF)
9 1/2"	3900	190
11 7/8"	3500	184
14"	3100	197
16"	2100	186

* Please contact EMERCOR's Customer Service Department for Limited States Design (LSD) Figures.

IMPORTANT: FAILURE TO INSTALL EMERCOR INSULATED RIMBOARD ACCORDING TO INSTRUCTIONS WILL VOID THE PRODUCT WARRANTY. LOCAL BUILDING CODE REQUIREMENTS APPLY.

For Technical Assistance and Product Information
Call 1-866-EMERCOR
www.emercor.com

EMERCOR Ltd.
104 Commercial Court
Calgary, Alberta CANADA T3Z 2A5
© 2006 EMERCOR Ltd. Printed in CANADA

STORAGE AND HANDLING

Provide adequate and even support for panels when storing. Ensure panels are stored in a flat position and are well covered and protected from the weather. Handle panels with care. For more information on the proper storage and handling of Insulated Rimboard, please see the Product Care Guide on www.emercor.com.

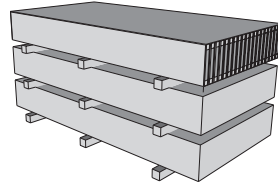

DO NOT INSULATE

Do not apply batt insulation to inside face. Spray foam and foam facing can be applied. Phone manufacturer with questions 1-866-EMERCOR.

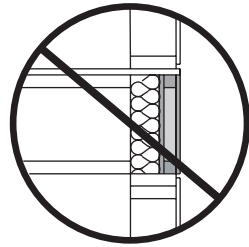

LAMINATION GUARANTEE

EMERCOR Ltd. guarantees to the purchaser that EMERCOR polyurethane structural insulated panel products carry a fifty year lamination warranty commencing from the date of purchase. EMERCOR will repair or replace free of charge any part or parts of the product, if the defect is due to the fault material or manufacturer workmanship. For full lamination guarantee visit www.emercor.com.



SQUASH BLOCK REQUIRED AT ALL POINT LOADS

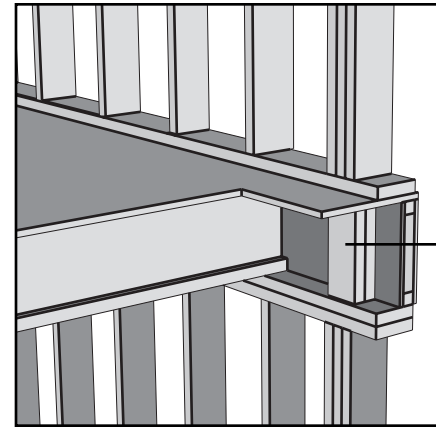

Fasten blocking with 3" box nails on both top and bottom chords of Insulated Rimboard.

PENETRATIONS

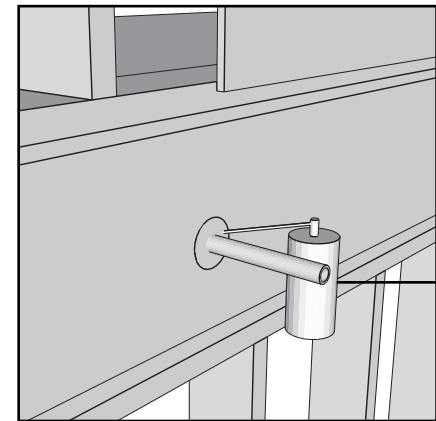

Foam and caulk all penetrations through Insulated Rimboard with *polyurethane spray foam. Do not penetrate insulated Rimboard below the point loads.

FASTENING REQUIREMENTS

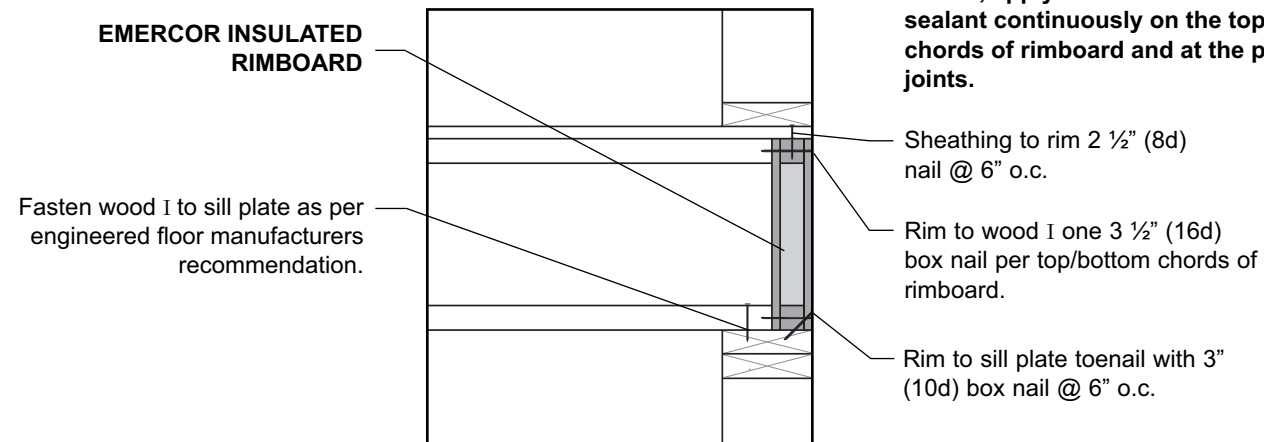

To maintain the integrity of the air/vapor barrier, apply construction adhesive/sealant continuously on the top/bottom chords of rimboard and at the panel joints.

NOTE: Join connections with 1 1/2" staples, 2" nails or 2" #8 screws @ 6" o.c. both sides of panel.

IMPORTANT: FAILURE TO INSTALL EMERCOR INSULATED RIMBOARD ACCORDING TO INSTRUCTIONS WILL VOID THE PRODUCT WARRANTY. LOCAL BUILDING CODE REQUIREMENTS APPLY.

OVERHANG REQUIREMENTS

0" - 1" Overhang

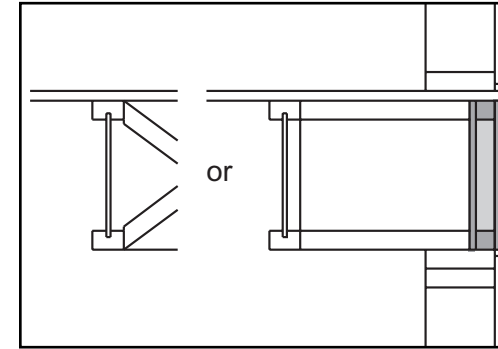

0" Overhang

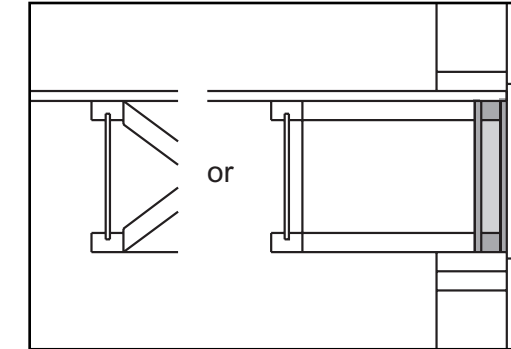

NOTE: Lateral support for floor joists/trusses to be determined by floor designer.

Use joist lock or equivalent to connect blocking panel to joist.

INSTALLATION SEQUENCE - FEMALE/MALE CONNECTION

STEP #1: Cut Starter Panel

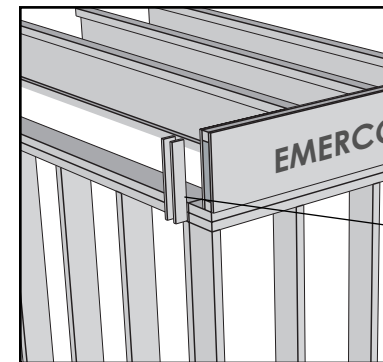

Cut female connection off starter panel - 2"

STEP #2: Joining Panels

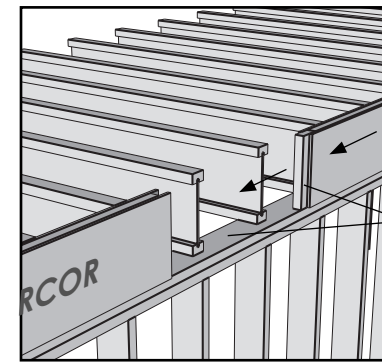

Apply construction adhesive/sealant and join panels according to Fastening on Page 2. Panels do not have to join at an I-Joist.

STEP #3: Typical Corner

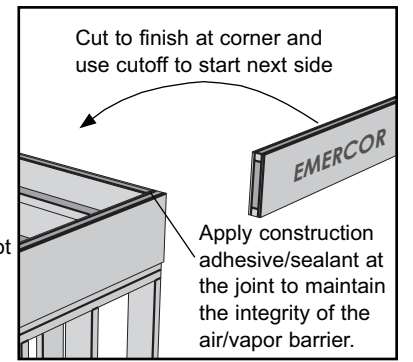

Cut to finish at corner and use cutoff to start next side

Apply construction adhesive/sealant at the joint to maintain the integrity of the air/vapor barrier.

NEW - INSTALLATION SEQUENCE WITH LAP JOINT

STEP #1: Cut Starter Panel

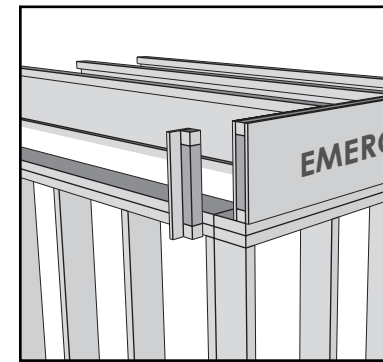

STEP #2: Joining Panels

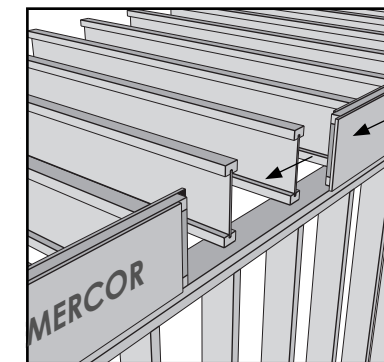

TOP VIEW

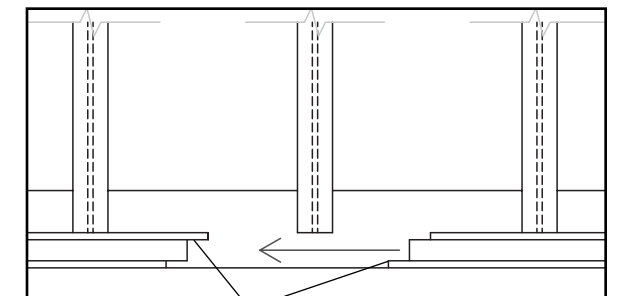

Apply construction adhesive/sealant to inside skins and join panels according to Fastening on Page 2. The panels do not have to join at an I-Joist.

IMPORTANT: FAILURE TO INSTALL EMERCOR INSULATED RIMBOARD ACCORDING TO INSTRUCTIONS WILL VOID THE PRODUCT WARRANTY. LOCAL BUILDING CODE REQUIREMENTS APPLY.